



Duodopa[®]
LEVODOPA/CARBIDOPA INTESTINAL GEL

abbvie
care 
with you

DUODOPA[®] GUIDE FOR PATIENTS

Levodopa/Carbidopa Intestinal Gel

abbvie

INTRODUCTION TO DUODOPA

What's in this booklet?

This information booklet is designed to help both yourself and your carer(s) to better understand and operate the Duodopa pump. When you arrive home from hospital it is important that you look after your pump, connectors and PEG-J site. This booklet lists the important information regarding the procedures you'll need to follow. You will also find information on how to start the pump in the morning and disconnect the pump in the evening, as well as a handy troubleshooting section in the event that an alarm goes off. If you have any questions or concerns about Duodopa, please tell your neurologist or Parkinson's disease nurse. Keep this booklet handy so you can refer to it easily.

What is Duodopa?

Duodopa is a combination of Levodopa/Carbidopa used to treat advanced Parkinson's disease. The Duodopa 100 mL cassette is connected to a portable pump and the medication is continuously infused throughout the day. Duodopa is delivered through a PEG-J into the small intestine where the medication is absorbed. This, unlike oral medications, is designed to provide a steady, continuous dose of the medication to help maximise the control of your symptoms.



DUODOPA CADD-LEGACY® PUMP

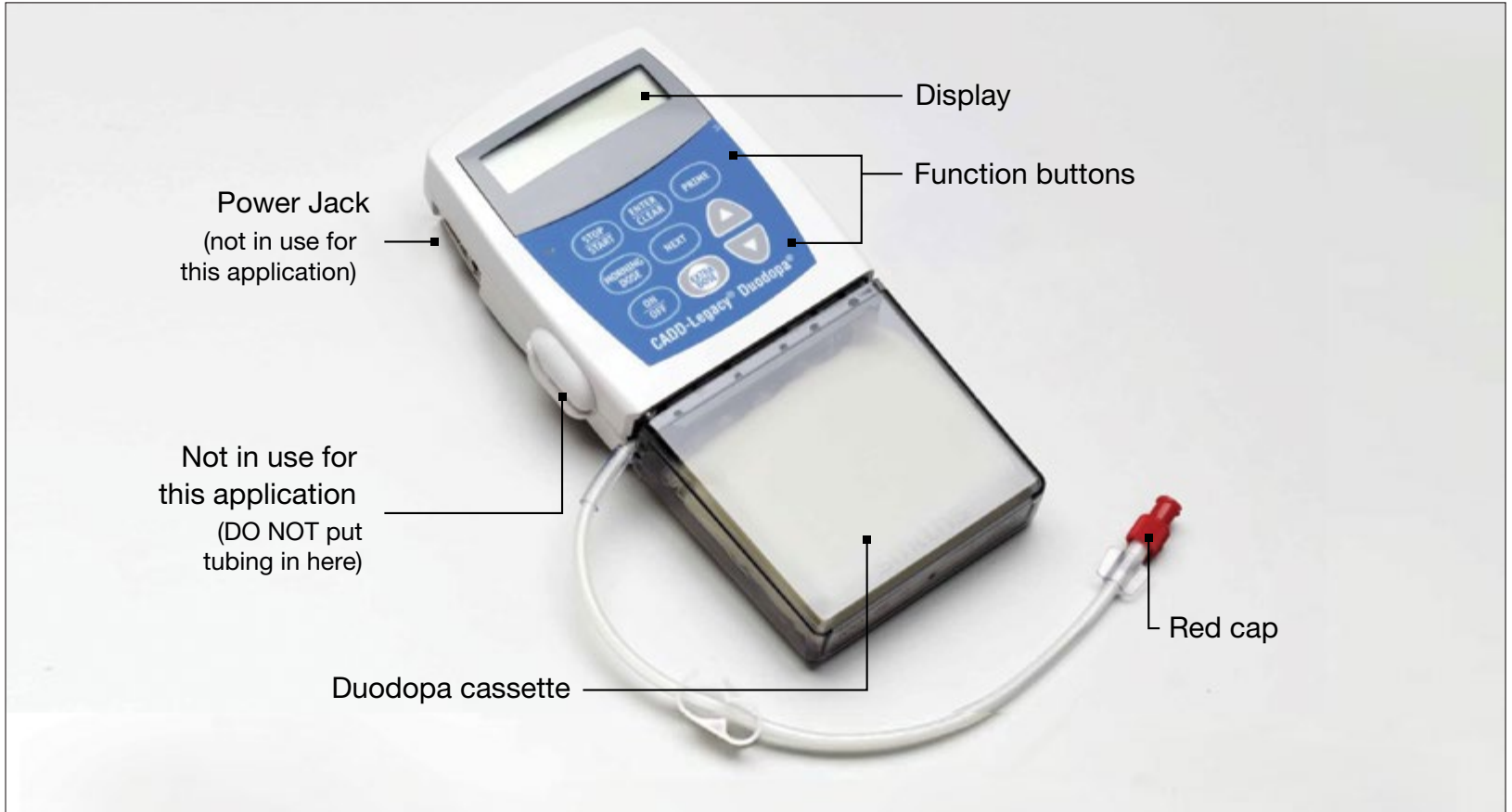

DUODOPA MORNING ROUTINE

1. Take the Duodopa cassette out of the fridge at least 20 minutes before starting the pump.
2. Attach the Duodopa cassette to the pump as shown:
 - Fit the hooks of the cassette onto the pivot pins at the pump's base.
 - Place the pump upright on a firm, flat surface. Press down so the cassette fits tightly against the pump.
3. Insert the key into the slot in the cassette latch, push in, and turn counter clockwise until the line on the latch lines up with the arrow on the side of the pump and you feel the latch click into place.

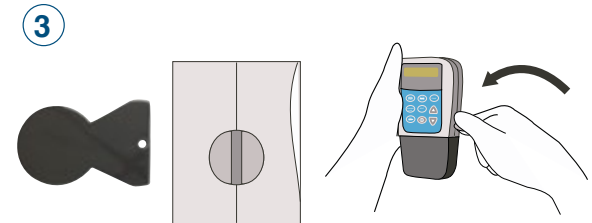
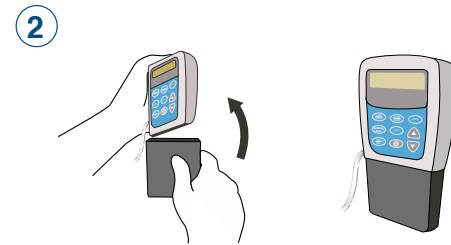
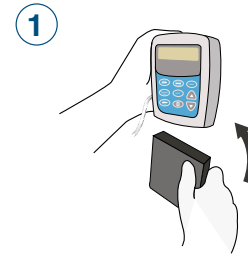

DUODOPA MORNING ROUTINE

4. Remove the stopper from the PEG-J tube.
5. Remove the **RED** cap from the cassette tubing.
6. Connect the cassette tubing to the PEG-J tube. **Do this by securely holding the PEG-J tube with one hand whilst gently rotating the cassette tube clockwise onto the PEG-J with the other hand.**

DO NOT twist your PEG-J tube, as this may dislodge your tubing internally.

Do all the twisting with the cassette tubing not the PEG-J tubing.

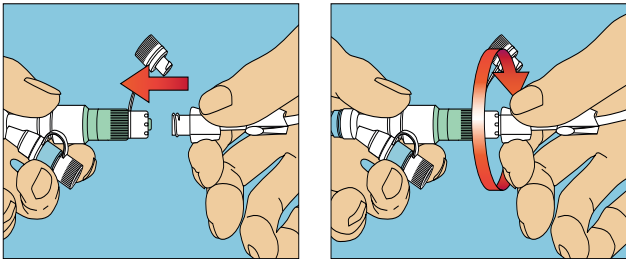

4



The appearance of the gastric port may differ in colour. The white gastric port will be either blue or violet.

5



DUODOPA MORNING ROUTINE

7. Press and hold the  button (keep pressed for 3 seconds). The pump runs the program and displays the set values.

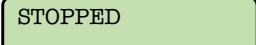
This takes approx. 30 seconds and  will be displayed.

8. Press and hold the  button and keep pressed until  disappears.

The pump runs through the set values again. This takes approx. 15 seconds. Then  will appear.



9. Press the  button (the preset dose is displayed).

10. Press the  button again. The pump now administers the set Morning Dose and then automatically starts the continuous dose. Secure the pump safely in an appropriate carrying device .

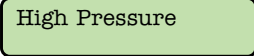
NB: Ensure all clamps are open or pump will alarm

 High Pressure

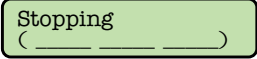
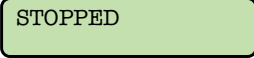
DUODOPA EVENING ROUTINE

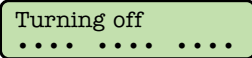
1. Press the  button until  disappears and  is displayed.
2. Press and hold the  button until  is displayed.
3. Disconnect the used Duodopa cassette and tubing from the PEG-J tube. Do this by securely holding the PEG-J tube with one hand whilst gently rotating anti-clockwise, then remove the cassette tube from the PEG-J with the other hand.

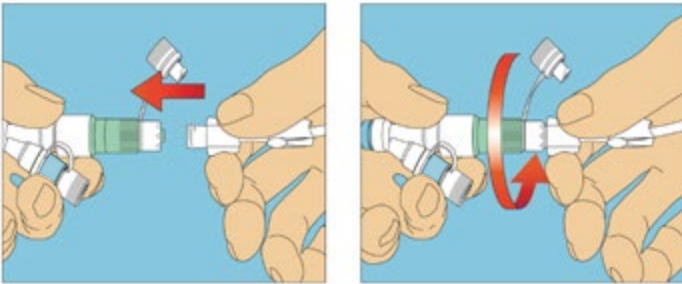

DUODOPA EVENING ROUTINE

4. Attach the blue luer-lock adaptor to the syringe. Flush the PEG-J tube intestinal port with a 20 mL syringe with at least 20 mL room temperature tap or drinking water. Normally the first few mL are difficult to flush through. Connect the Luer lock stopper.

**NB: The tube has a capacity of 3 mL (60 mg Levodopa).
You will receive this as a dose when flushed.**

5. Flush the PEG-J tube gastric (Y-connector) port with a 20 mL syringe with at least 20 mL room temperature tap or drinking water. Normally the first few mL are difficult to flush through. Connect the Luer lock stopper.

6. Discard the used cassette even if not empty.

NB: These instructions are based on clinical experience and should be considered as a guide only. Final decisions for patient care remain that of the treating doctor.

4

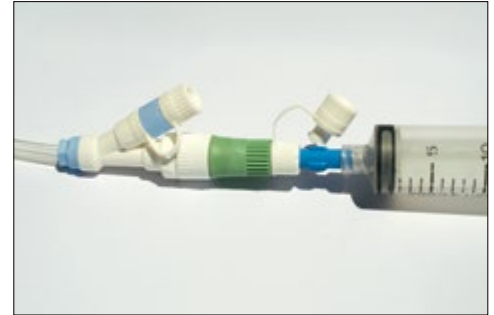

5



The appearance of the gastric port may differ in colour. The white gastric port will be either blue or violet.

SHOWERING ROUTINE

Never get the pump wet.

Please stop the pump and disconnect the tubing before showering. Leave the pump outside of the showering area as steam may affect the functionality of the pump.

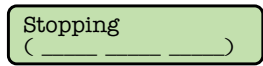
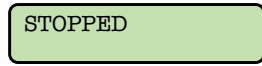
1. Press and hold the  button until  disappears and  is displayed
This will put the pump in a hold mode.
2. Disconnect the Duodopa tubing from the PEG-J tube and cap both tubes.
3. The PEG-J site can be cleaned whilst showering with soap and water.
4. The pump will sound reminder beeps every 5 minutes. This is normal and will continue to do so until it is reconnected and started after showering.

SHOWERING ROUTINE

5. On a daily basis, after the stoma has healed, remove the tubing from the external retention plate. Gently move the tubing into the stomach by approximately 3-4 cm in a bi-directional motion (back and forth) and carefully pull back up to the resistance of the internal retention plate. Secure the tubing back into the external fixation plate about 5-10 mm from the skin. Do not rotate or turn the tube to prevent the formation of loops and dislocation of the tube.
6. Ensure the PEG-J site is dry after showering, to prevent infection of the site.
7. Connect the cassette tubing to the patient again (remember to remove the **RED** cap).

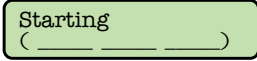

8. Press and hold the  button and keep pressed until  disappears.

The pump runs through the set values again. This takes approx 15 seconds.

9. The pump will now run at the set continuous rate. It will display 

NB: As the pump is stopped before showering you will be without any medication during this period. Therefore there is the option to use the extra dose before and after showering. To do this press extra dose by pressing the button once and allow a few minutes or so for the dose to deliver before disconnecting.

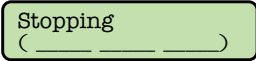
REPLACING BATTERIES IN THE PUMP

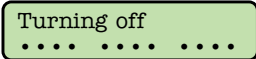
- The Duodopa pump requires 2 x AA alkaline batteries. **(do not use rechargeable batteries).**
 - Batteries should be replaced weekly.
1. To turn the pump off – Press the  button and hold it down for 3 seconds until  is displayed.
 2. Press the  button (hold it down) until  is displayed.
 3. Press and hold the arrow marked button on the battery cover.
 4. Slide the battery cover open.
 5. Remove the used batteries. (It is easier if you pull the battery strap).
 6. Align the new batteries + and - marks with corresponding mark inside the battery compartment and place the batteries over the battery strap. When the batteries are in the correct position the pump will beep.
 7. Replace the battery cover. The pump will start automatically.

NB: Ensure the batteries match the + and – marks or nothing will be displayed.
Batteries for the pump are ordered through AbbVie Customer Service
Ph: 1800 230 608.

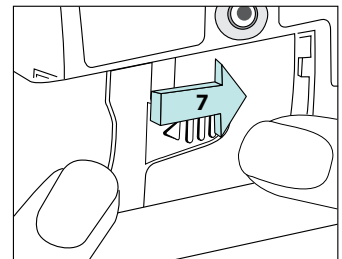
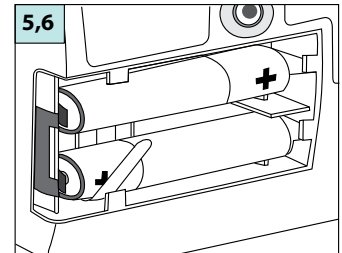
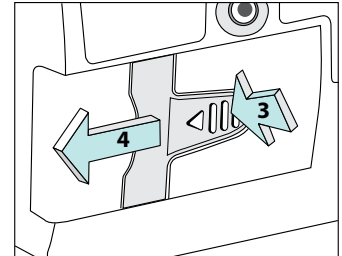

STORAGE OF DUODOPA

- Duodopa cassettes should be stored in the refrigerator between 2° to 8°C. **DO NOT FREEZE DUODOPA.**
- Take care not to place Duodopa cassettes too close to any freezing elements in your fridge as Duodopa cannot be used if it becomes frozen.
- Always transport Duodopa cassettes in an insulated esky, especially on a hot day, and never leave them in your car.
- Duodopa is sensitive to light therefore always keep it in its original carton.
- Duodopa cassettes have a relatively short shelf life (15 weeks). Always check the expiry when you receive your Duodopa and before use. Take care to store older supplies near the front and use these first to avoid any stock expiring.
- The Duodopa cassette must be discarded after it has been at room temperature for 16 hours.
- Each cassette is for single use only. Discard any unused product.
- In the event of spillage Duodopa will stain. Wash area immediately.

NB: Please notify your pharmacy and AbbVie if you cease Duodopa so your orders can be cancelled.

TECHNICAL PUMP DATA

- Do not operate the pump at temperatures below 2°C or above 40°C. Keep the pump at room temperature for at least an hour prior to use.
- Do not store the pump at temperatures below -20°C or above 60°C. Do not store the pump with the Duodopa cassette attached. Use the protective cassette provided.
- Do not expose pump to humidity levels below 20% or above 90% relative humidity.
- Do not immerse the pump in cleaning fluid or water, or allow solution to soak into the pump, accumulate on the keypad, or enter the battery compartment.
- Use a normal soap solution when cleaning the pump. Do not clean it with acetone, other plastic solvents, or abrasive cleaners.
- Do not store the pump for prolonged periods of time with the batteries installed. Battery leakage could damage the pump.
- Do not expose the pump to therapeutic levels of ionizing radiation during therapeutic radiation sessions, ultrasound, magnetic resonance imaging equipment or hyperbaric chambers as this may cause damage to the pump.
- The pump may interfere with ECG equipment. Monitor ECG equipment carefully when using this pump.

PEG-J AFTERCARE

Aftercare following discharge from Hospital

- Always wash and dry hands before handling your PEG-J tube.
- Cleanse the site with soap and water daily. This can be done as part of your daily showering routine.
- **Do not** use any hydrogen peroxide or iodine - based products (e.g.: Betadine®) or any other special cleansers on the site.
- Rinse PEG-J site well and pat dry. **NB: Area should be left completely dry.**
- When cleaning the site, look for any redness of the skin or discharge around the site. Notify your nurse and doctor if this is present as this may indicate infection or irritation.

Daily:

1. Flush the PEG-J tube intestinal port using a 20 mL syringe, with at least 20 mL of room temperature tap or drinking water at night after disconnecting the pump. This will prevent the tube from blocking.
2. Flush your PEG-J gastric port (Y-connector), using a 20 mL syringe, with at least 20 mL of of room temperature tap or drinking water.
3. Gently move your tubing into the stomach by approx. 3-4 cm and carefully pull back up to the resistance of the internal retention plate. Secure the external fixation plate about 5-10 mm from the skin. Secure the tube onto the plate.

①

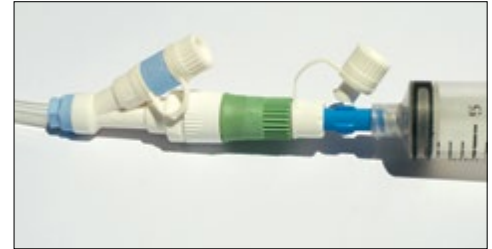

②



NB: Continuous care of PEG-J tubing should be performed EVERY DAY after initial wound healing.

The appearance of the gastric port may differ in colour. The white gastric port will be either blue or violet.

PEG-J AFTERCARE

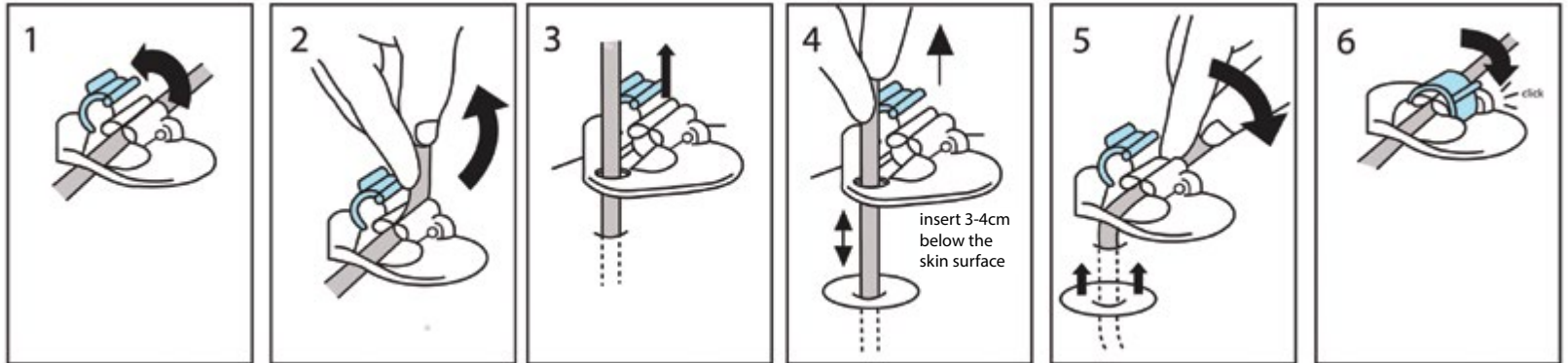

1. Open the blue clamp and release the external fixation plate.
2. Loosen the tube from the plate.
3. Gently pull the external fixation plate upwards. Wash with mild soap and water and dry thoroughly.
4. Gently push tubing into the stomach 3-4 cm and move the tube in a bi-directional motion (back and forth). Do not twist or rotate the tube.
5. Return the external fixation plate to approximately 5-10 mm from the skin. Secure the tube onto the plate.
6. Close the blue clamp.

PEG-J AFTERCARE

NB: Do not rotate the tube, as this may dislodge the intestinal tube which may result in hospitalisation for a replacement.

- If your tube is dislodged, try to push the tube back in and secure. Contact your doctor/Parkinson's disease nurse immediately to confirm if any further action is required. If the tubing is completely out, cover the site with a sterile dressing and contact your doctor/Parkinson's disease nurse immediately.

PUMP ALARMS

The pump is equipped with a number of different alarms, which will warn you when an action is required or when an error needs to be corrected.

Please check the pump display window to find out what the alarm is.

Alarm	Cause	Action
High pressure Two-tone alarm	The pump has detected high pressure, which may be due to a downstream blockage, kink in the fluid path, or a closed clamp.	<ol style="list-style-type: none"> 1. Remove the obstruction (if known) to resume operation. OR <ol style="list-style-type: none"> 2. Press STOP/START or NEXT to stop the pump and silence the alarm for two minutes, then remove the obstruction and restart the pump.
LowBat (Low Battery) Three two-tone alarm beeps every five minutes	The batteries are low, but the pump is still operating.	<ol style="list-style-type: none"> 1. Change batteries without delay. 2. Press and hold STOP/START to restart the pump.
[blank display] Two-tone alarm	The batteries have been removed while the pump is running. The pump is now stopped and unpowered. OR Batteries were removed within 15 seconds after the pump was stopped.	<ol style="list-style-type: none"> 1. Install new batteries to silence the alarm, if desired. Otherwise, the alarm will stop within a short period of time.

PUMP ALARMS

Alarm	Cause	Action
RUN ResVolLow Three single beeps	The Duodopa cassette reservoir volume is low. The daily allowance may have been exceeded. The pump calculates that 5 ml remains in the cassette (reservoir). Each cassette contains 100 mL.	<ol style="list-style-type: none"> 1. Check the cassette volume. If empty, prepare to stop the pump as daily allowance has been exceeded. Install a new cassette if appropriate.
Reservoir volume empty Two-tone alarm	The cassette reservoir volume has reached 0.0 mL and the pump has stopped.	<ol style="list-style-type: none"> 1. Press STOP/START or NEXT to silence the alarm. 2. Change to a new cassette if required and reset the reservoir volume.
Error Two-tone alarm	An error has occurred.	<ol style="list-style-type: none"> 1. Remove the pump from use. Contact your PD clinic as the pump needs to be returned for service.
Battery depleted Two-tone alarm	The battery power is too low to operate the pump. The pump is now stopped.	<ol style="list-style-type: none"> 1. Change batteries immediately. Press and hold STOP/START to restart the pump.
Upstream occlusion Two-tone alarm	Duodopa is not flowing from the cassette to the pump.	<ol style="list-style-type: none"> 1. Press STOP/START or NEXT to stop the pump and silence the alarm for two minutes. 2. Check for a kink in the tubing or a closed clamp between the cassette and the pump. 3. Remove the obstruction and press STOP/START to restart the pump.

PUMP ALARMS

Alarm	Cause	Action
<p>No disposable, clamp tubing Two-tone alarm</p>	<p>The cassette has been removed, therefore the pump is not sensing correct cassette attachment.</p>	<ol style="list-style-type: none"> 1. Press STOP/START or NEXT to silence the alarm. 2. Clamp or disconnect tubing from PEG-J tube. The cassette must be properly attached in order for the pump to run
<p>Screen displays current pump status Two beeps, long and short</p>	<p>Potential causes: The Duodopa reservoir is not aligned with the pump or Duodopa is not flowing from the medication bag inside the Duodopa reservoir to the pumping mechanism. OR The medication may be very cold or extremely thick which may cause this informational message as well.</p>	<ol style="list-style-type: none"> 1. Press STOP/START or NEXT to silence the alarm. 2. Make sure the Duodopa reservoir is properly aligned with the pump and Duodopa is flowing from the medication bag to the pumping mechanism. OR Allow Duodopa to reach room temperature before connecting cassette to the pump.
<p>No Disposable, Pump won't run Two-tone alarm</p>	<p>You have tried to start the pump without a cassette attached. A cassette must be correctly attached in order for the pump to run.</p>	<ol style="list-style-type: none"> 1. Press STOP/START or NEXT to silence the alarm. 2. Connect the cassette properly.
<p>Service due Two-tone alarm</p>	<p>The pump is functional but is due for service based on clock battery age or total motor revolutions.</p>	<p>The screen appears in LLO for 60 days and then in all lock levels until returned for service.</p> <ol style="list-style-type: none"> 1. Contact your PD clinic as the pump needs to be returned for service.

PUMP ALARMS

Alarm	Cause	Action
<p>Value not saved</p>	<p>A value was not saved by pressing ENTER/CLEAR.</p>	<ol style="list-style-type: none"> 1. Press NEXT to resume programming. 2. Save the value before moving on to the next screen before starting the pump.
<p>Programming incomplete</p> <p>Two-tone alarm when starting the pump</p>	<p>A rate or dose must be programmed to start the pump.</p>	<ol style="list-style-type: none"> 1. Press STOP/START or NEXT to clear the alarm.
<p>Power lost while pump was on</p> <p>Two-tone alarm</p>	<p>The pump was running when power was removed.</p>	<ol style="list-style-type: none"> 1. Stop the pump before changing the batteries or removing the power source. 2. Press STOP/START or NEXT to clear the alarm.
<p>Key pressed, please release</p> <p>Two-tone alarm</p>	<p>If a key is being pressed, stop pressing it.</p>	<p>If alarm persists:</p> <ol style="list-style-type: none"> 1. Close the tubing clamp and remove the pump from use. 2. Contact your PD clinic as the pump needs to be returned for service.
<p>Stopped</p> <p>Three single beeps every 5 minutes</p>	<p>The pump is stopped. Stopping the pump stops delivery e.g. taking a shower.</p>	<ol style="list-style-type: none"> 1. When the pump is stopped, STOPPED will appear on the main screen, and you will hear 3 beeps every 5 minutes. Reconnect the pump to yourself and resume the pump by using the STOP/START button.

CONNECTORS

How connectors are assembled

When PEG-J is in correct position, please ensure connectors are put on in correct order from 1-6

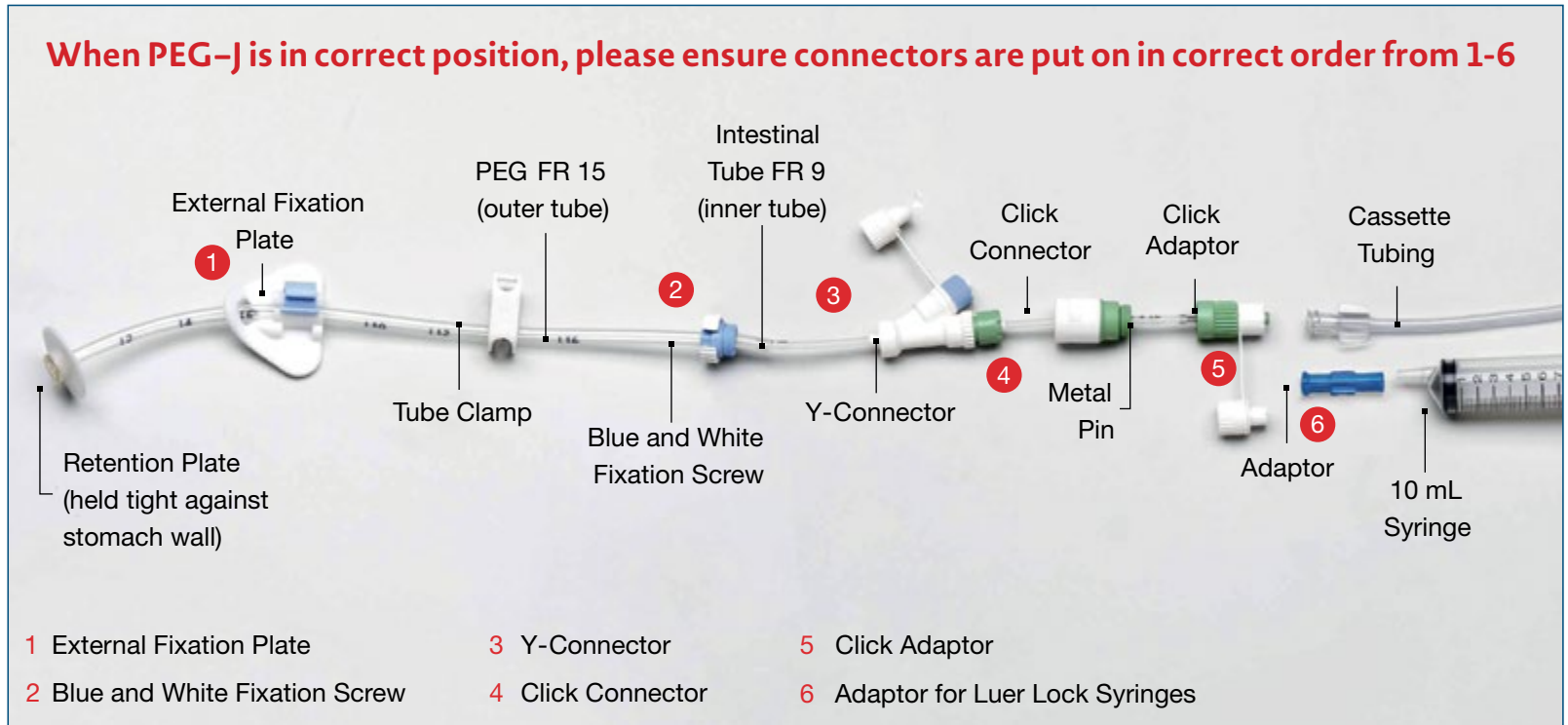

NOTE: The appearance of the gastric "g" port of the Y-Connector may differ in colour. The white "g" port will be either blue or violet, depending on the FR being used (15 or 20 FR kit).

BLOCKED DUODOPA INTESTINAL TUBE

A blocked tube may be indicated by the following:

1. Tubing difficult to flush.
2. High pressure alarm that will not resolve.

In these events, it is suggested the push-pull technique to be used to try to flush the tube.

Equipment required:

- 20 mL syringe
- Adaptor for luer-lock syringes
- 50 mL warm tap water
- Underpad/towel

BLOCKED DUODOPA INTESTINAL TUBE

1. Draw up 20 mL of warm water with a 20 mL syringe.



2. Attach the luer-lock adaptor to the syringe. Place towel over lap to prevent any spillage.



3. Connect the syringe with the adaptor attached to the intestinal port (at the stomach) of the PEG-J tube and plunge the tube with a push-pull technique several times.

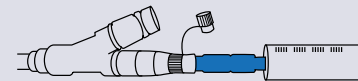

BLOCKED DUODOPA INTESTINAL TUBE

4. Repeat the previous step with another 20 mL of warm water to ensure tube is free of any blockages. This step should be repeated for 20 minutes or up to 1 hour.



5. If this technique does not free the blockage, contact the PD clinic so they can arrange for an X-ray to check the tubing inside your abdomen (do not forget to take a adaptor for Luer-Lock syringe with you).

A 3-way tap can also be used (available at most hospitals)

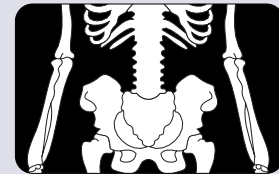

6. If the port is blocked your doctor you may advise to temporarily stop your Duodopa treatment. Follow your doctor's instruction and refer to the Interrupted Duodopa Treatment section of this guide for more information.



PROBLEMS /COMPLICATIONS OF PEG-J

General:

- Circular redness diameter of <0.5 cm is normal and not necessarily a sign of wound infection (careful daily observation is required and contact your doctor immediately if it worsens).
- Never apply an ointment on a PEG-J stoma or an inflamed PEG-J wound.

Problem	Action
Encrusted dressing	Remove with 0.9% normal saline solution.
Signs of inflammation	Monitor the site for redness or discharge. Contact the doctor immediately if it worsens.
Severe discharge	Keep the wound as dry as possible. Note the colour and frequency of discharge. Contact the doctor/gastroenterology team.
Overgrown Granulation Tissue	Is when excess tissue growth can occur around the PEG-J site. This needs to be reported to the doctor/stoma nurse. This may be removed to avoid complications.
Blocked tube	Flush slowly with the push/pull technique using a 20 mL syringe of warm water. Contact the doctor/stoma nurse if unable to clear the tubing.
Dislodged tube	Contact the doctor immediately. Consider X-ray to find the positioning of the tube.
Abdominal pain	Observe for signs of perforation or peritonitis such as fever, prolonged abdominal pain or nausea and vomiting. Contact the doctor immediately.

INTERRUPTED DUODOPA TREATMENT

The following dose equivalence tables are for replacement Levodopa/Carbidopa therapy using oral tablets during interrupted Duodopa infusion therapy, caused by technical problems with the pump or tubing. Please note that this is only intended for temporary replacement therapy and not for long term use.





































It is important to ask your doctor which drug is suitable for you and how to select the correct dose according to your current Duodopa morning and continuous dose. The dose depends on your individual symptoms and response to the drug. This may vary considerably from patient to patient. Please confirm the maximum allowable dose per day with your doctor.

Please refer to the dose equivalence tables using either Madopar® or Sinemet® on the following pages:

Madopar® 125 contains 100 mg Levodopa / 25 mg Benserazide



















Sinemet® 100/25 contains 100 mg Levodopa / 25 mg Carbidopa

INTERRUPTED DUODOPA TREATMENT

Morning Dose						
Duodopa infusion (mL)	Approx Equivalent Levodopa Dose (mg)	Approximate Equivalent Oral Dose				
5.5 to 7	50 to 80	 to 	½-1 Madopar 125	OR	 to 	½-1 Sinemet 100/25
7.1 to 8	82 to 100		1 Madopar 125			1 Sinemet 100/25
8.1 to 10	102 to 140	 to  	1-1½ Madopar 125		 to  	1-1½ Sinemet 100/25
10.1 to 12.5	142 to 190	  to  	1½-2 Madopar 125		  to  	1½-2 Sinemet 100/25
12.6 to 15	192 to 240	  to   	2-2½ Madopar 125		  to   	2-2½ Sinemet 100/25
15.1 to 16.5	242 to 270	  	2½ Madopar 125		  	2½ Sinemet 100/25

Levodopa equivalent doses for the Morning Dose are calculated by considering the 3 mL PEG-J Intestinal tube volume and the concentration of Duodopa gel (20 mg Levodopa/5 mg Carbidopa per mL).

INTERRUPTED DUODOPA TREATMENT

Continuous Infusion Rate (Maintenance Dose)						
Duodopa infusion (mL)	Approx Equivalent Levodopa Dose (mg)	Approximate Equivalent Oral Dose Administered every 2 hours				
1.5 to 2	30 to 40	 to 	1/2-1 Madopar 125	OR	 to 	1/2-1 Sinemet 100/25
2.1 to 3	42 to 60		1 Madopar 125			1 Sinemet 100/25
3.1 to 4	62 to 80	 to 	1-1 1/2 Madopar 125		 to 	1-1 1/2 Sinemet 100/25
4.1 to 5.5	82 to 110	 to 	1 1/2-2 Madopar 125		 to 	1 1/2-2 Sinemet 100/25
5.6 to 7	112 to 140	 to 	2-2 1/2 Madopar 125		 to 	2-2 1/2 Sinemet 100/25

Levodopa equivalent doses for the Continuous Dose are calculated using the concentration of Duodopa gel (20 mg Levodopa/5 mg Carbidopa per mL) and adjusted for change from hourly infusion rates to 2 hourly oral dosing.

MY CONTACT DETAILS

My doctor has prescribed me:

Morning dose: _____ mL

Continuous dose: _____ mL per hour

Extra dose: _____ mL

My Duodopa healthcare team

Neurologist: _____ Phone: _____

PD Nurse: _____ Phone: _____

Gastroenterologist: _____ Phone: _____

GP: _____ Phone: _____

Pharmacist: _____ Phone: _____

If you are admitted back to hospital please ensure you take your Duodopa cassettes with you.

If you have any questions regarding your Duodopa medication, please always consult your doctor.

This guide is for patients prescribed Duodopa.
It is not designed to replace the advice of your healthcare professional.
Please consult your doctor for further information.

Please call 1800 230 608 for all enquiries

AbbVie Pty. Ltd. 241 O’Riordan Street, Mascot NSW 2020. AU-DUOD-220003 March 2022

